

**Horizontally curved ducts(Custom-made products)**

- 3P/5P, 30A
- Coupling plate set, conductor splice and cover included.
- Hot-dipped galvanized steel

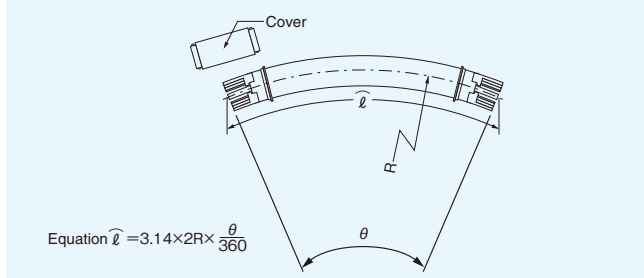

Type	Rating	Minimum R	Available duct length $\widehat{l}$
602	3P30A	20A trolley : 800mm	500mm(min.) to 1800mm(max.)
		40A trolley : 1,000mm	
1004	5P30A	20A trolley : 1,000mm	

Note: Custom-made products.

- 3P/5P, 60A
- Coupling plate set, conductor splice and cover included.
- Hot-dipped galvanized steel

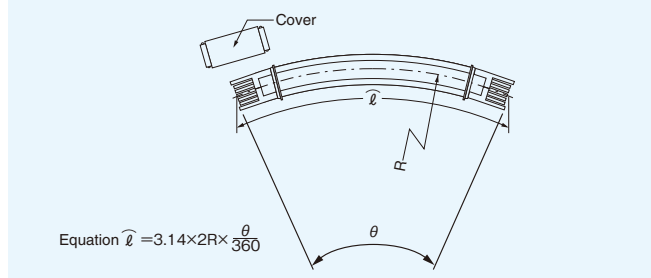

Type	Rating	Minimum R	Available duct length $\widehat{l}$
602	3P60A	20A trolley : 800mm	500mm(min.) to 1800mm(max.)
		40A trolley : 1,000mm	
1004	5P60A	20A trolley : 1,000mm	

Note: Custom-made products.

**Feed-in boxes**

- 3P, 30A/60A
- Coupling plate set, terminals and cover included.
- Knockout diameter:  $\phi 26.1$ ,  $\phi 32.5$
- Hot-dipped galvanized steel

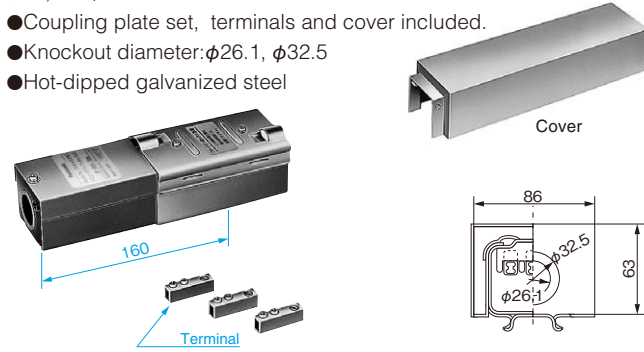

Cat. No.	Type	Rating	Weight (kg)
DH6572	602	3P30A-60A	1.5

- 5P, 30A/60A
- Coupling plate set, terminals and cover included.
- Knockout diameter:  $\phi 32.5$ ,  $\phi 38.8$
- Hot-dipped galvanized steel

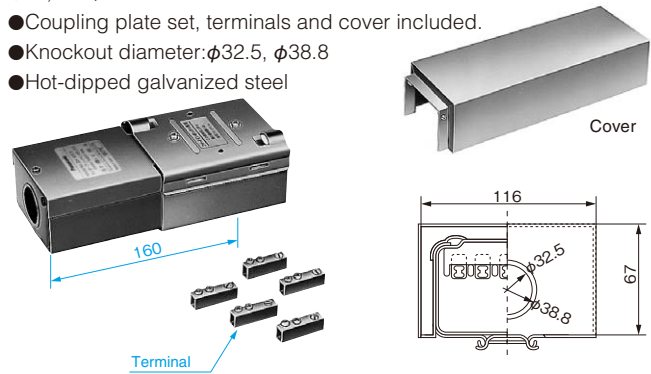

Cat. No.	Type	Rating	Weight (kg)
DH6592	1004	5P30A-60A	1.6

**Center feed-in boxes**

- 3P, 30A/60A
- Cover included.
- Crimp-on terminals (14mm<sup>2</sup>) and cover included.
- Knockout diameter:  $\phi 26.1$ ,  $\phi 32.5$
- Hot-dipped galvanized steel

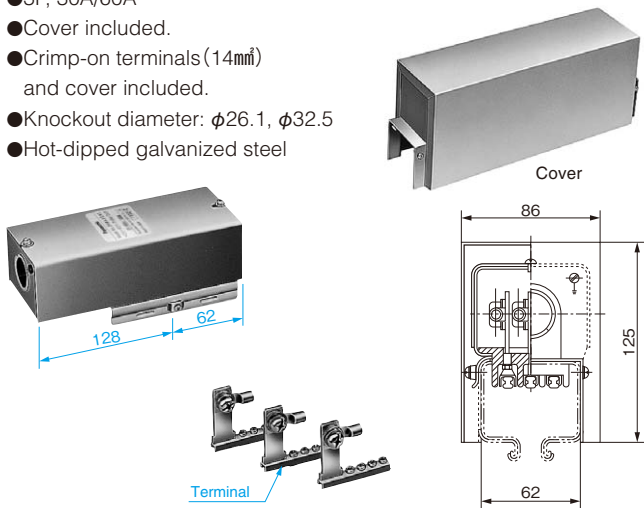

Cat. No.	Type	Rating	Weight (kg)
DH6573	602	3P30A-60A	1.3

- 5P, 30A/60A
- Cover included.
- Crimp-on terminals (14mm<sup>2</sup>) and cover included.
- Knockout diameter:  $\phi 32.5$ ,  $\phi 38.8$
- Hot-dipped galvanized steel

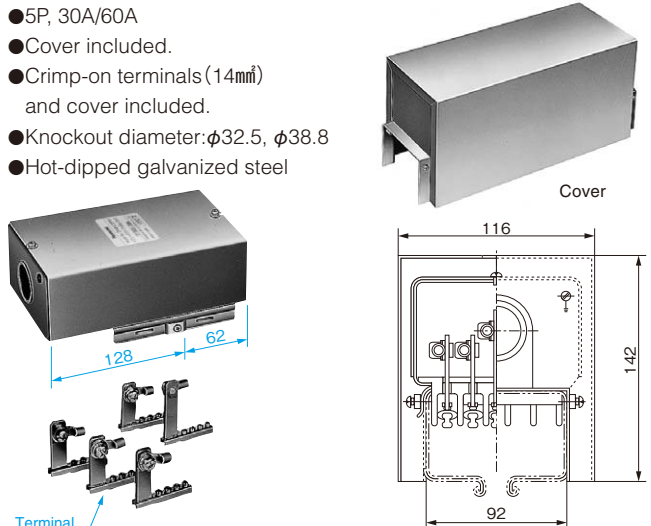

Cat. No.	Type	Rating	Weight (kg)
DH6593	1004	5P30A-60A	1.6

Unit : mm

### End caps

- 3P, 30A/60A
- Cover included.
- Hot-dipped galvanized steel

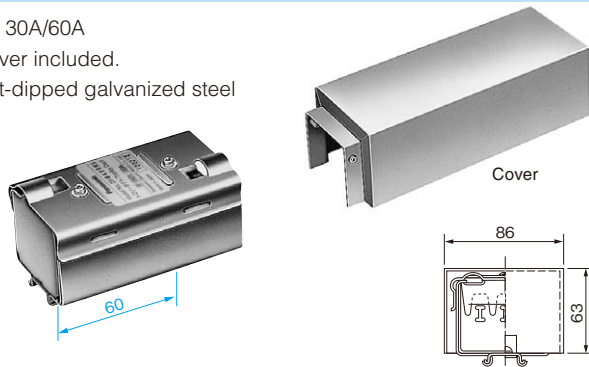

Cat. No.	Type	Rating	Weight (kg)
DH6512	602	3P30A·60A	0.6

- 5P, 30A/60A
- Cover included.
- Hot-dipped galvanized steel

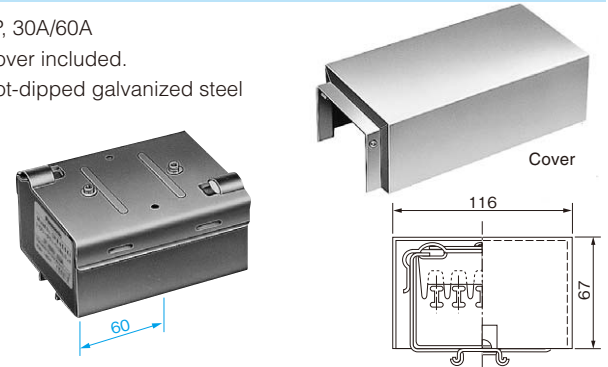

Cat. No.	Type	Rating	Weight (kg)
DH6514	1004	5P30A·60A	1.1

### Hangers

- For 2P/3P, 30A/60A ducts

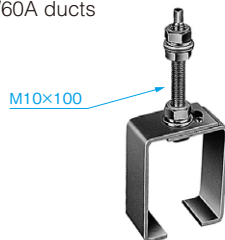

Cat. No.	Type	Weight (kg)
DH6111	602	0.3

- For 4P/5P, 30A/60A ducts

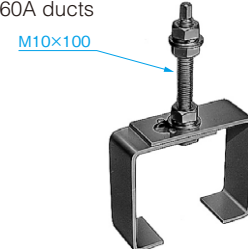

Cat. No.	Type	Weight (kg)
DH6411	1004	0.4

### Horizontal-traverse hangers

Used in locations where the duct moves or turns along with the device, such as a crane's lateral travel.

- For 2P/3P, 30A/60A ducts

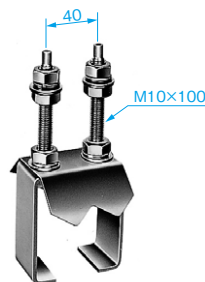

Cat. No.	Type	Weight (kg)
DH6113	602	0.6

- For 4P/5P, 30A/60A ducts

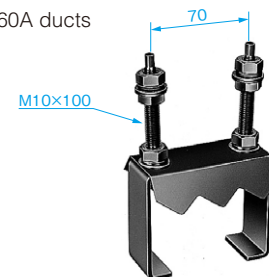

Cat. No.	Type	Weight (kg)
DH6413	1004	0.8

### Outdoor-type trolleys



3.5mm crimp-on terminals included.

Cat. No.	Type	Product name	Compatible ducts
DH6275	602	3P20A trolley	3P30A·60A ducts



3.5mm crimp-on terminals included.

Cat. No.	Type	Product name	Compatible ducts
DH6295	1004	5P20A trolley	5P30A·60A ducts

Note: 4P type is custom-made.



8mm crimp-on terminals included.

Cat. No.	Type	Product name	Compatible ducts
DH6576	602	3P40A trolley	3P60A ducts

Note: 2P type is custom-made.

Note: 2P type is custom-made.

# Outdoor-type Trolley Ducts

100A 600V

The rain-proof construction makes these Trolley Ducts suitable for outdoor installations.

Unit : mm

## Straight-line duct

- 3P, 100A
- Coupling plate set, conductor splice and cover included.
- Hot-dipped galvanized steel

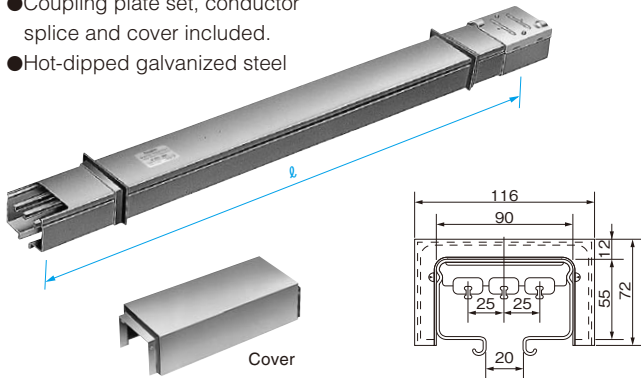

Cat. No.	Type	Rating	Standard length( l )	Weight (kg)
DH6933K2	1004	3P100A	3,000	15.0

Note: In addition to the standard 3m length, other lengths can also be made to order (500mm minimum to 3m maximum). 2P type is custom-made.

## Drop-out duct

- 3P, 100A
- Coupling plate set, conductor splice and cover included.
- Hot-dipped galvanized steel

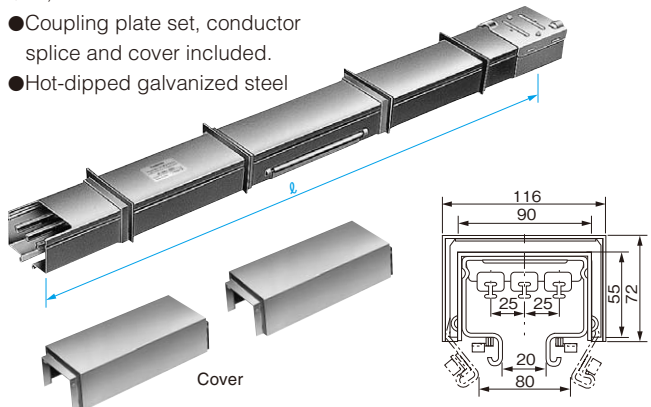

Cat. No.	Type	Rating	Standard length( l )	Weight (kg)
DH6943K2	1004	3P100A	1,000	5.2

Note: In addition to the standard 1m length, other lengths can also be made to order (800mm minimum). 2P type is custom-made.

## Horizontally curved duct(Custom-made products)

- 3P, 100A
- Coupling plate set, conductor splice and cover included.
- Hot-dipped galvanized steel

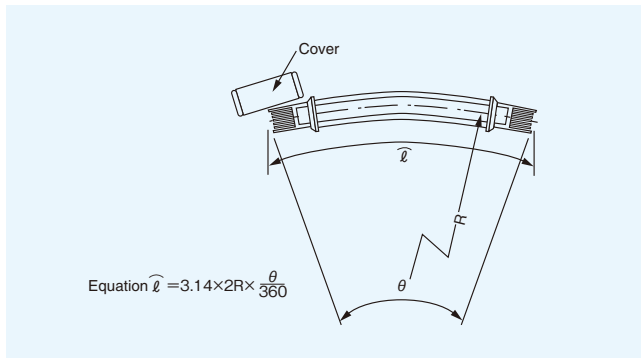

Type	Rating	Minimum R	Available duct length l-hat
1004	3P100A	40A trolley: 1,000mm 80A trolley: 2,500mm	500mm(min.) to 1800mm(max.)

Note: Custom-made products.

## Feed-in box

- 3P, 100A
- Coupling plate set, terminals and cover included.
- Knockout diameter:  $\phi 32.5$ ,  $\phi 38.8$
- Hot-dipped galvanized steel

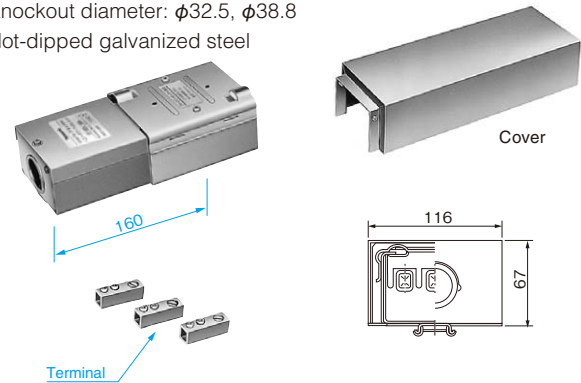

Cat. No.	Type	Rating	Weight (kg)
DH6953	1004	3P100A	1.6

## End cap

- 3P, 100A
- Cover included.
- Hot-dipped galvanized steel

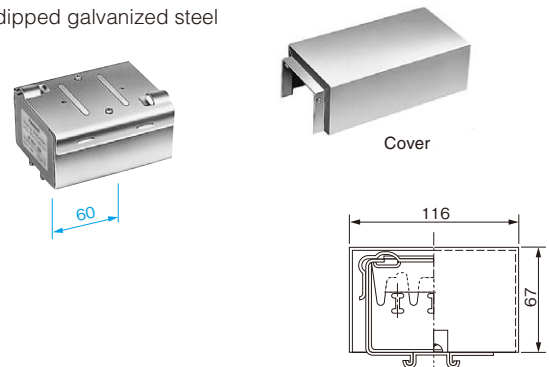

Cat. No.	Type	Rating	Weight (kg)
DH6515	1004	3P100A	1.1

## Center feed-in box

- 3P, 100A
- Cover included.
- Solderless terminals (38mm) and cover included.
- Knockout diameter:  $\phi 32.5$ ,  $\phi 38.8$
- Hot-dipped galvanized steel

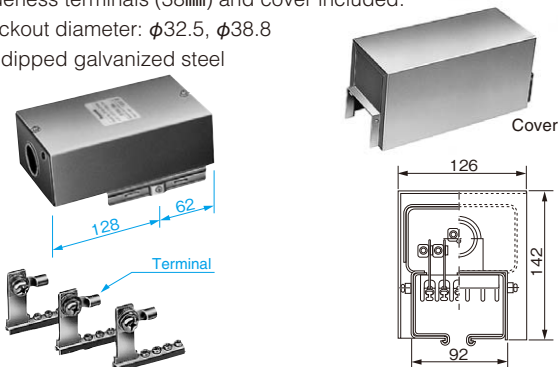

Cat. No.	Type	Rating	Weight (kg)
DH6963	1004	3P100A	1.5

Unit : mm

### Hanger

- For 3P, 100A ducts

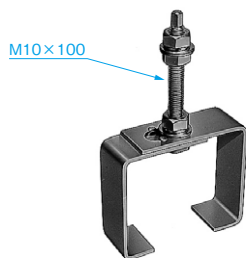

Cat. No.	Type	Weight (kg)
DH6411	1004	0.4

### Sideway-traverse hanger

Used in locations where the duct moves or turns along with the device, such as a crane's lateral travel.

- For 3P, 100A ducts

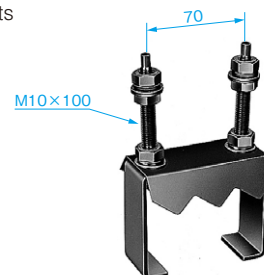

Cat. No.	Type	Weight (kg)
DH6413	1004	0.8

### Outdoor-type trolley



8mm pressure terminals included.

Cat. No.	Type	Product name	Compatible ducts
DH6676	1004	3P40A trolley	3P100A ducts

Note: 2P type is custom-made.

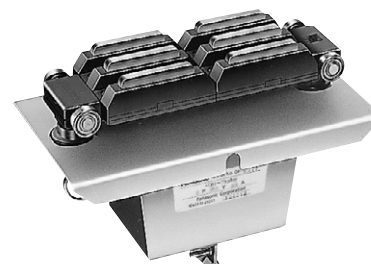

Without pressure terminals.

Cat. No.	Type	Product name	Compatible ducts
DH6696	1004	3P80A trolley	3P100A ducts

Note: 2P type is custom-made.