

1 Making a bracket available

Brackets for mounting the trolley supporting hanger are not provided by Panasonic Electric Works Co., Ltd. Commercially available angles should be used.

Duct rating		Bracket
2P	AC 300V 30A	L-40×40×5
3P	AC 300V 60A	
4P	AC 300V 30A	
5P	AC 300V 60A	
2P	AC 600V 100A	
3P	AC 600V 100A	

● Standard bracket dimensions 30A/60A/100A

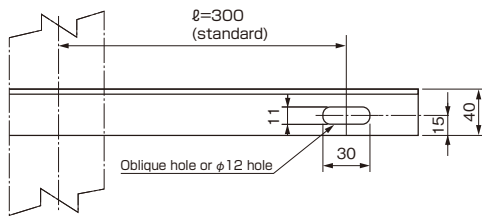

⚠ Caution

● If brackets other than those shown above are to be used, the brackets must be of a material with strength equal to or surpassing the specified brackets, otherwise the Trolley Duct may fall. Determine "l" dimensions by taking the relationship with the device in use into consideration.

2 Installing brackets

1. Determine the bracket installation positions making sure that the hanger positions will not coincide with the Trolley Duct connections or drop-out duct openings for trolley insertion.
2. Install the brackets on I-beams or other building structures.

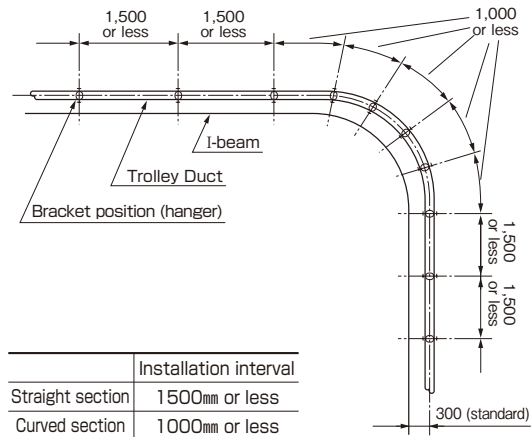

⚠ Caution

- Standard installation intervals for brackets are shown above.
- Make sure to use at least one hanger for each duct, otherwise the duct may fall.
- Make sure to use at least two hanger for curved duct.

3 Installing the hangers

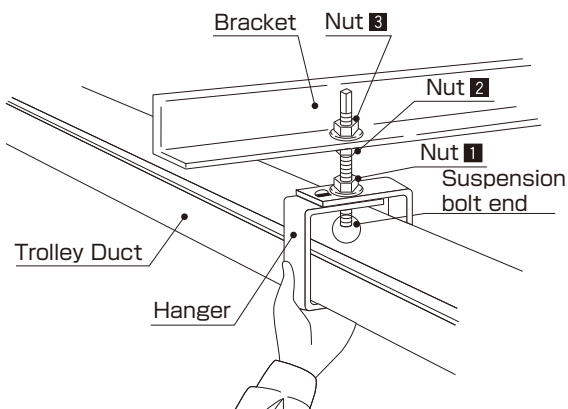

1. Mount the hanger onto the bracket and temporarily secure the Trolley Duct as shown. Turn the bolt until its end slightly contacts the duct upper surface and tighten the nut 1 to secure the duct.

Notes

- Before fastening the nut 1, check to see there is no gap between the hanger side face and duct side face. Otherwise, the duct may be fallen down.
- When the nut 1 to secure the duct, please warn that the bolt turns together.
- When the suspension bolts closed too much, there is a threat that the opening of the trolley duct becomes small.

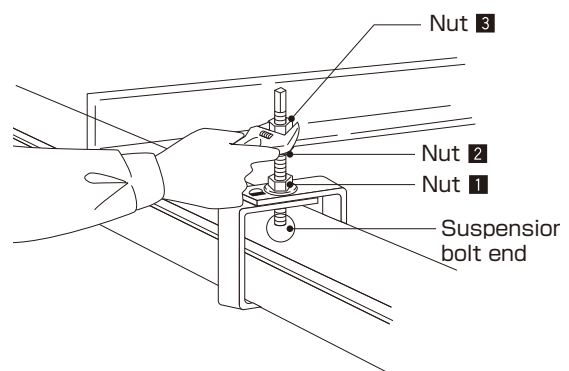

2. Adjust duct height with the nut 3 and connect the sections of the duct. Securely attach the hanger to the bracket by tightening the nut 2. Make sure to tighten the nut 2 securely; otherwise the duct may fall.

Notes

- For Trolley Duct connection, see section "4 Connecting the Trolley Duct sections."
- Check to see that the centers of the hangers and ducts are aligned correctly with each other; otherwise poor contact may occur or the trolley may separate from conductors.
- Fix the hanger precisely on the bracket.

4 Connecting the Trolley Duct sections

Standard of construction accuracy

1. Horizontal construction accuracy 2. Vertical direction construction accuracy

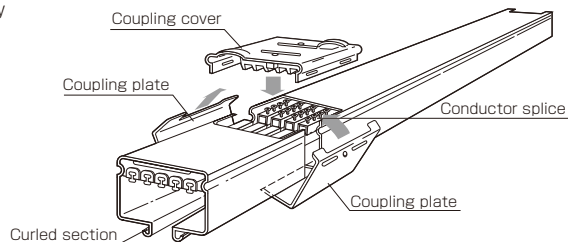
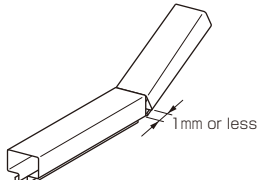
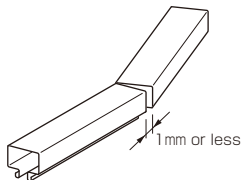

(Drawing shows a 5P Trolley Duct.)

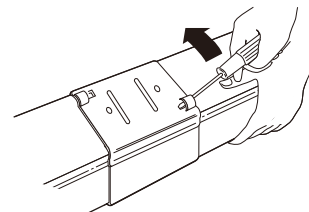
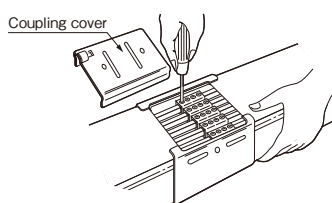
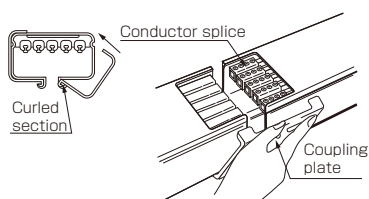

1. Insert the conductor splice to the conductor and connect the duct sections, and install the right and left coupling plates over the curled section as shown. Make sure to fit the left and right plates over the curled section correctly; otherwise the duct may fall.

2. Move the conductor splice to the center of the connection section and tighten the screws securely. Then install the coupling cover. Screws must be tightened securely in order to avoid any danger from fire. Do not mount forcibly include a center shift, otherwise the conductor is twisted, and burr occurred on conductor or doing so may result in fire. (Tightening torque: 1.0 to 1.5N.m)

〈Removing the coupling cover〉
The coupling cover can be removed easily by inserting a screwdriver into the hook of the coupling cover and lifting it up.

5 Installing the end cap

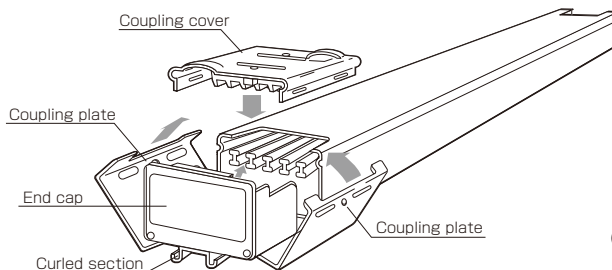

(Drawing shows a 5P Trolley Duct.)

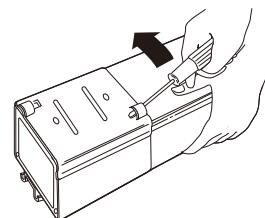
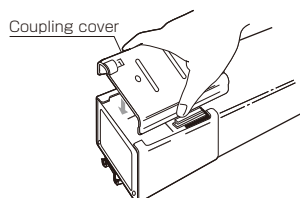
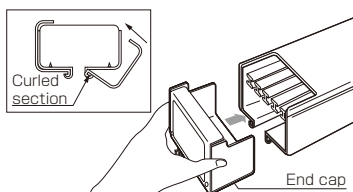

1. Fit the end cap onto the end of the duct and fit the left and right coupling plates over the curled section. Make sure to fit the left and right plates over the curled section correctly; otherwise the duct may fall.

2. Mount the coupling cover.

〈Removing the coupling cover〉
The coupling cover can be removed easily by inserting a screwdriver into the hook of the coupling cover and lifting it up.

6 Installing the feed-in box

Trolley Duct type			Size of fitted flexible conduit	Cross section area of fitted wire
Rated voltage	Rated current	No. of poles		
AC 300V	30A	2 · 3	30	22mm ²
	60A	4 · 5	38	22mm ²
AC 600V	100A	2 · 3	38	38mm ²

Caution

- Please decide the use electric wire in consideration of the load capacity etc. There is fear of a fire.
- Agreement flexible conduit changes by the electric wire used, and select it according to the electric wire, please.

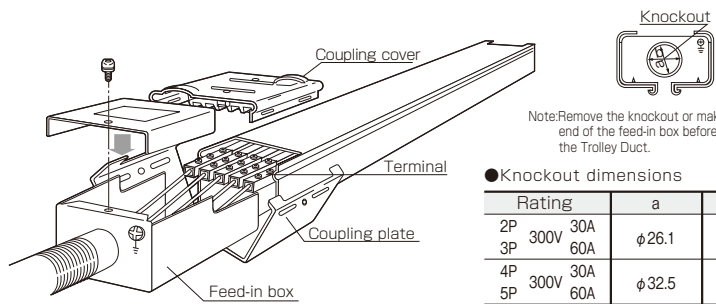

(Drawing shows a 5P Trolley Duct.)

● Knockout dimensions

Rating		a	b
2P	30A	φ26.1	φ32.5
3P	60A		
4P	30A	φ32.5	φ38.8
5P	60A		
2P	600V100A	φ32.5	φ38.8
3P			

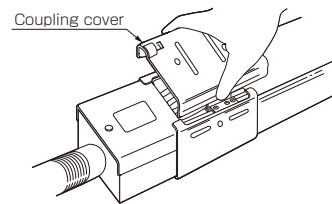
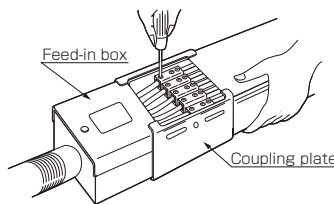
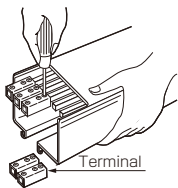

1. Insert the terminal to the conductor and tighten the screws securely. Fit the feed-in box onto the duct and install the left and right coupling plates over the curled section. Install the coupling plates securely over the curled section; otherwise the Trolley Duct may fall. (Tightening torque: 1.0 to 1.5N.m)

2. Connect wires to the feed-in box terminal board. Hi-Flex (class 2 metal flexible conduit) is most appropriate for piping. Make sure to connect the wires to the terminal board correctly by securely tightening the terminal screws; otherwise fire may result. (Tightening torque: 1.0 to 1.5N.m)

3. Install the coupling cover. To remove the coupling cover, insert a screwdriver into the hook of the coupling cover and lift it up.

7 Installing the center feed-in box

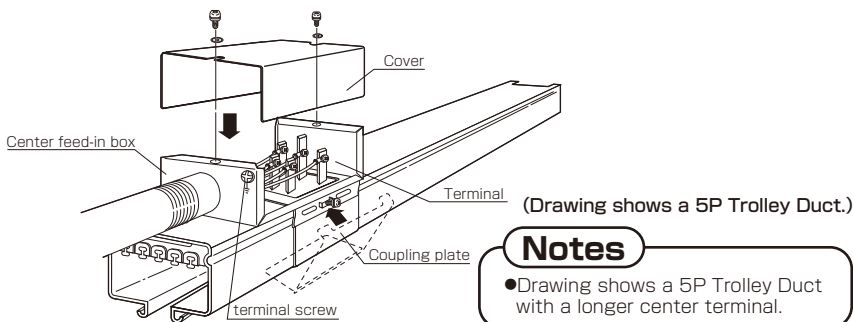

Notes

- Drawing shows a 5P Trolley Duct with a longer center terminal.

● Knockout dimensions

Rating		a	b
2P	AC 300V 30A	φ26.1	φ32.5
3P	60A		
4P	AC 300V 30A	φ32.5	φ38.8
5P	60A		
2P	AC 600V100A	φ32.5	φ38.8
3P			

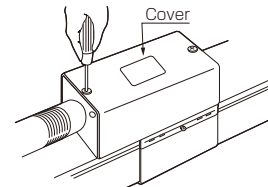
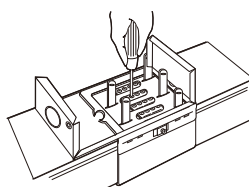
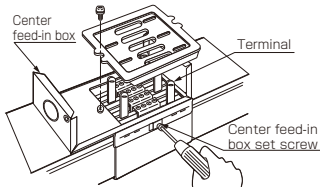

1. Insert the terminals into the conductor as shown. Install the coupling plates, fit the cover and tighten the feed-in box set screws. Correctly install the coupling plates over the curled section; otherwise the Trolley Duct may fall.

2. Secure the terminals to the conductor. Hi-Flex (class 2 metal flexible conduit) is most appropriate for piping. (Tightening torque: 1.0 to 1.5N.m)

3. After wire connections, place the cover.

Notes

- Tighten the terminal screws securely; otherwise fire may result.

8 Wiring

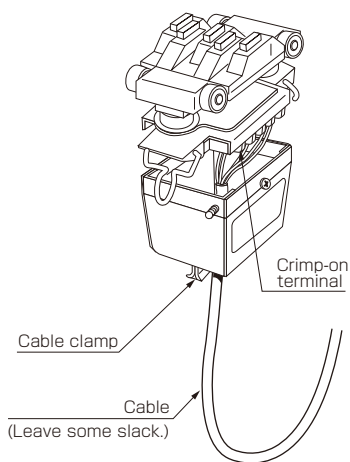

■ Connecting wires to the trolley

Use cabtire cables for the cables, and fasten them securely using crimp-on terminals. A 20A trolley comes with 3.5mm² crimp-on terminals; a 40A trolley comes with 5.5mm² crimp-on terminals. (However, for an 80A trolley, the cables should be connected directly to the terminals.)

When installing the cables, be sure to use the cable clamp to hold them securely.

Notes

- Tighten terminal screws securely. (Tightening torque: 1.0 to 1.5N·m)
- Do not hang anything other than the power cables from the trolley.
- Leave sufficient slack in the cables so that the trolley does not tilt during travelling.

● Use cabtire cables for cables.

Trolley type		Compatible cables	
Rated voltage	Rated current	No. of poles	No. of cores × nominal cross-sectional area × No. of cables
AC 300V	20A	2	2 cores × 0.75 to 5.5mm ² × 1
		3	3 cores × 0.75 to 5.5mm ² × 1
		4	4 cores × 0.75 to 5.5mm ² × 1
	40A	4	2 cores × 0.75 to 5.5mm ² × 2
		5	3 cores × 0.75 to 5.5mm ² × 2
		5	4 cores × 0.75 to 3.5mm ² × 1
AC 600V	40A	2	2 cores × 0.75 to 8.0mm ² × 1
		3	3 cores × 0.75 to 8.0mm ² × 1
		4	4 cores × 0.75 to 8.0mm ² × 1
	80A	2	2 cores × 0.75 to 8.0mm ² × 2
		3	3 cores × 0.75 to 8.0mm ² × 2
		3	4 cores × 0.75 to 5.5mm ² × 1
		2 · 3	Single core × 8 to 30mm ² × 3

9 Installing and pulling the trolley

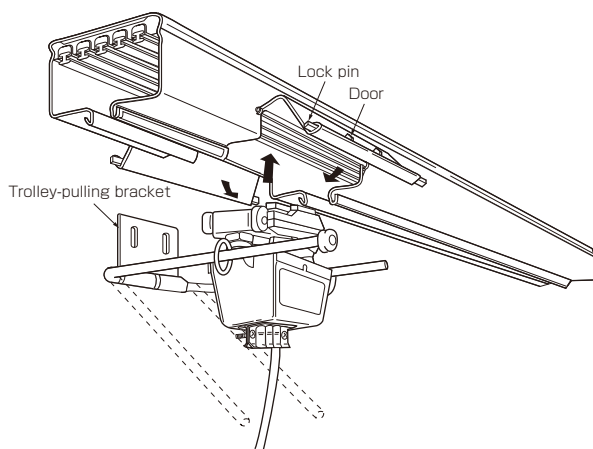

1. Insert the trolley into the opening of the drop-out duct. The opening of the drop-out duct can be opened by grasping the lock pin and unlocking it. After insert the trolley, securely close the opening. Incorrect locking may result in the trolley dropping down.
2. After insert the trolley, hand-move it about 30cm to check to see that it moves smoothly and the collector and the duct conductor correctly contact each other.

When using a chain (not supply goods)

Mount the chain to the pulling ring as following under drawing.

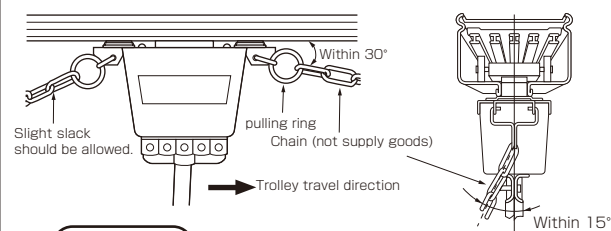

Notes

- Use that the chain angle is settled within the limits of the drawings. Not following the regulations may result in the imperfect contact and the trolley derailment.

10 Using the trolley-pulling bracket

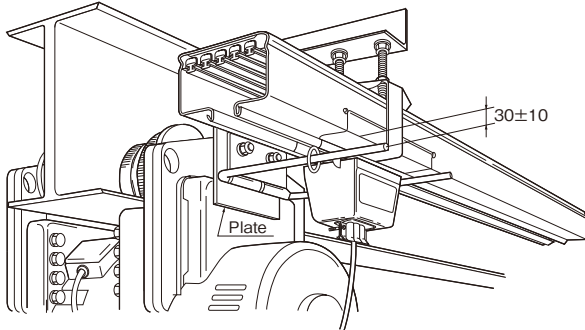

1. Tighten the trolley-pulling bracket to the plate attached to the crane or hoist using bolts. The plate should be purchased separately.
2. A 30mm space should be allowed between the duct bottom surface and the trolley-pulling bracket rod. Installation position can be adjusted by changing the securing base direction and using the oblique hole. Use M8 bolts.
3. Install the trolley-pulling bracket so that trolley-pulling bracket rod becomes it in parallel with an axle of the crane.

Notes

- Not travelling smoothly, the trolley tilt during the trolley, the trolley conductor is worn and the burrs occur.

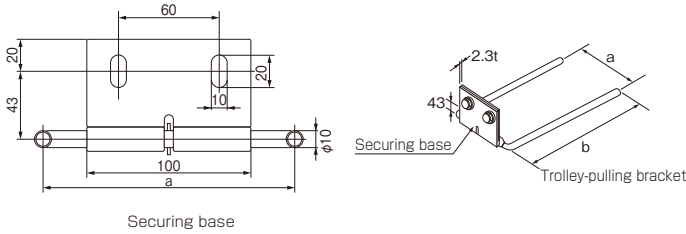

Unit:mm

Product name	Trolley-pulling bracket (A-1)	Trolley-pulling bracket (A-2)	Trolley-pulling bracket (B-1)	
Dimensions	a	145	145	200
	b	250	400	250
Compatible trolleys	2P20A 5P20A 4P40A	3P20A 2P40A 5P40A	4P20A 3P40A	2P80A 3P80A

11 Connecting trolleys

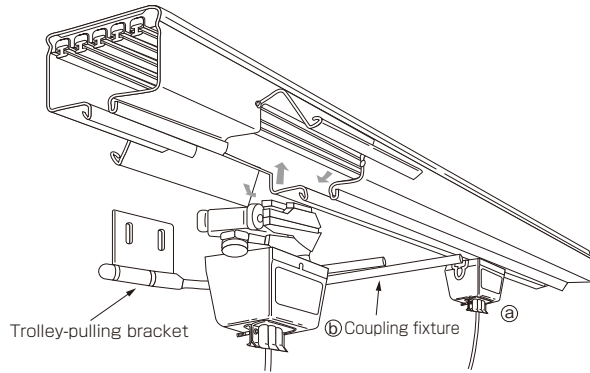
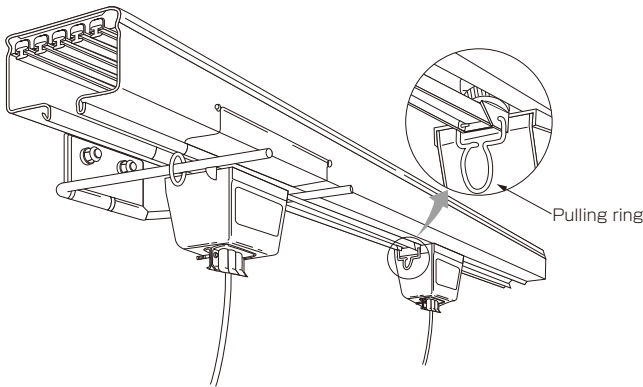

- When connecting two trolleys, install the trolley-pulling bracket onto one of the two trolleys.

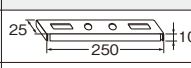
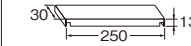
Product name	Dimensions and shape	Trolley rating
Coupling fixture A	25  10	2P20A·40A 4P20A·40A 5P20A·40A
Coupling fixture B	30  13	2P80A 3P80A

Unit:mm

1. Connecting two or more trolleys will facilitate smoother power collection in the following conditions. Use coupling fixtures when connecting trolleys.
 - ① When a single trolley cannot provide enough capacity.
 - ② When trolley's separation from conductors is a major problem. (When one trolley becomes separated from conductors, the other can compensate for it, and vice versa.)
 - ③ For point use. (There will be no dead sections at switching points of ducts.)
2. When mounting the coupling fixtures:
 - 1) Insert the trolley ① into the duct.
 - 2) Hook the coupling fixtures onto the rings of trolley ① and trolley ② and insert the trolley ② into the duct.
 - 3) When using the trolley-pulling bracket (A-2), do not use coupling fixtures.

12 Installing the pickup duct

● A pickup duct is used at the section where the trolley is inserted from space to within the trolley duct (such as on lines equipped with fire protection shutters, etc.) to enable the trolley to be smoothly inserted into the duct. In addition, for the trolley also, for this type of application use the UD-type trolley.

Notes

- For trolleys, use two UD-trolleys.
- Use two sideway traverse hanger on the duct of the pickup duct section.
- Installation and usage ranges should be kept within the range shown in Table 1. and C lever should be kept within the range shown Table 2.
- The installation positions for the sideway traverse hangers should be within 300mm from the pickup duct section.
- The distance from the pickup duct to the facing location should be a distance of at least 300mm.
- Installation interval of the UD-trolley should be a distance of at least 900mm, and should be a distance of at least 1500mm from the pickup duct section.

Table 1

Mounting position	a (level)	30A	For 2P/3P	100±3mm
		60A	For 2P/3P	
		30A	For 4P/5P	105±3mm
		60A	For 4P/5P	
	100A	For 2P/3P	0±2mm	
b (de-centering)				0±2mm

* Size a indicates the distance from the top surface of pickup duct to UD type trolley mounting hole.

Table 2

c (level)	30A	For 2P/3P	78±3mm
	60A	For 2P/3P	
	30A	For 4P/5P	83±3mm
	60A	For 4P/5P	
100A	For 2P/3P		

* Size c indicates the distance from the top surface of pickup duct to top panel of UD type trolley leaf spring.

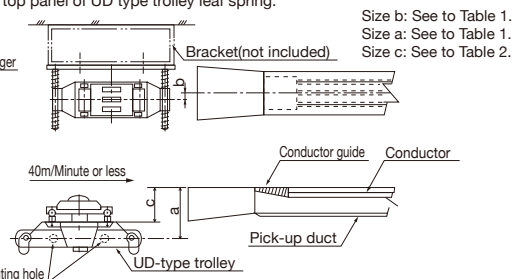
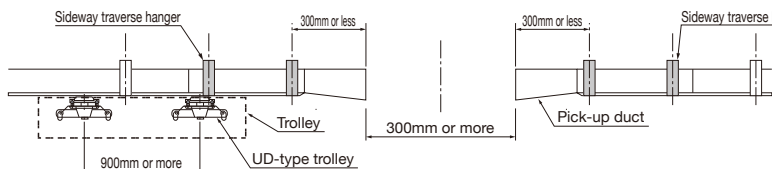

13 Installing the point duct

1. For trolleys, use two point trolleys and pull them separately using a pulling arm.
2. Use two sideway traverse hangers on the duct of the point duct section.
3. Installation standards should be kept within the ranges shown in Table 1.
4. The installation positions for the sideway traverse hangers should be within 150mm from the point duct section. However, for curved ducts, etc. where it is not possible to install the sideway traverse hangers within 150mm from the point duct section, the sideway traverse hangers should be installed as close as possible to the point duct section.

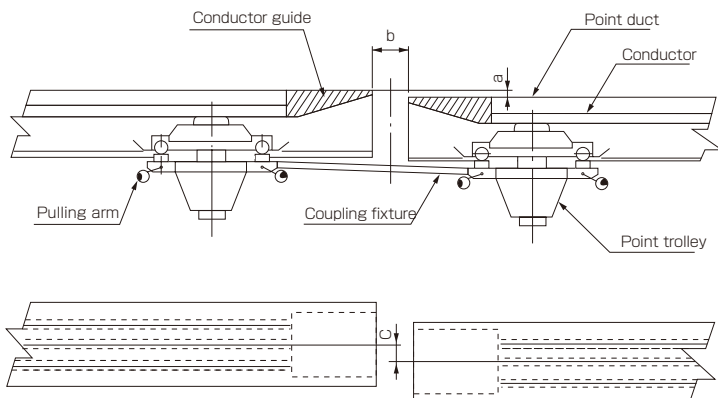
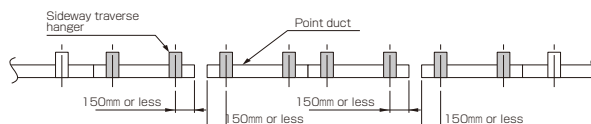

Table 1

Installation standards	
a (Level)	3mm以下
b (Gap)	10~30mm
c (Center shift)	3mm以下 b : (10~15mm)
	5mm以下 b : (16~30mm)

Sideway-traverse hangers

For applications where the I-beam or other structure onto which the Trolley Duct is installed is not stationary, but moves or rotates (e.g. crane girders, turntables, etc.), a sideway-traverse hanger capable of absorbing Trolley Duct vibration should be used, in order to avoid the duct dropping.

Installing the sideway-traverse hanger

Caution

- Press the ends of the sideway-traverse hanger suspension bolts against the duct upper surface.

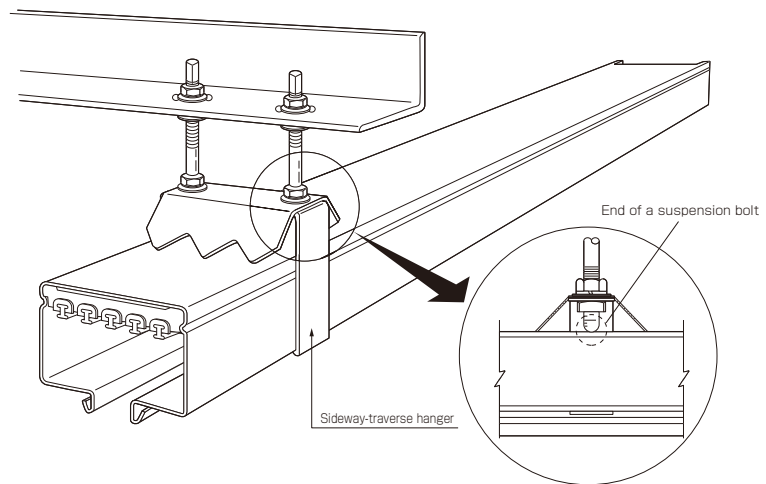

Locations where the sideway-traverse hanger should be used

① When using a point-use duct

- Traversers

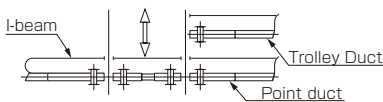

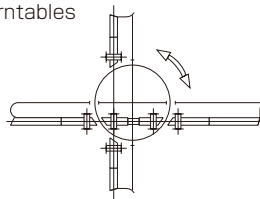

- Turntables

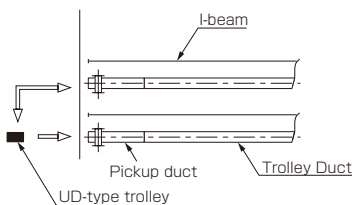

 : Locations where sideway-traverse hangers are used

② When using a pickup duct



 : Locations where sideway-traverse hangers are used

③ Trolley Duct for traverse movement

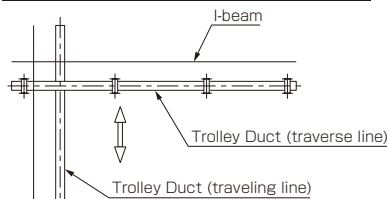

 : Locations where sideway-traverse hangers are used

④ Vertically curved duct

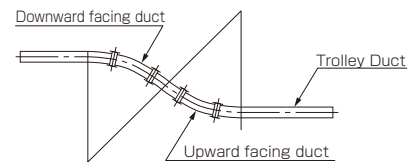

 : Locations where sideway-traverse hangers are used

Using the conductor cleaner

The conductor cleaner is a cleaning cart that removes some foreign substances, such as dust or burr adhering on the conductor sliding surface of the trolley duct so that the duct is always clean if you run it periodically.

■ Name of each part

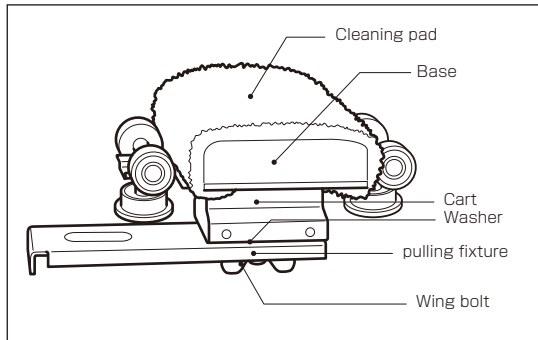

■ Types of conductor cleaner

There are two types depending on the trolley duct housing types, as follows:

Cat. No.	Product name	Suitable duct type and its rating
DH6166	Conductor cleaner 	 2P30A 3P30A 2P60A 3P60A
DH6202	Cleaning pad 10pcs/set	
DH6167	Conductor cleaner 	 4P30A 5P30A 4P60A 5P60A 2P100A 3P100A
DH6203	Cleaning pad 10pcs/set	

■ How to use

1. Open the opening of the drop-out duct and insert the conductor cleaner into the duct.

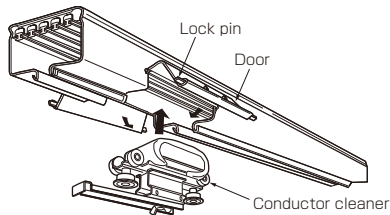

3. After cleaning, remove the conductor cleaner from the duct and use an air blower, etc. to clean inside the duct.

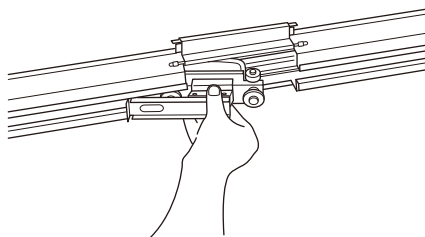

2. Run the conductor cleaner back and forth about 5 times to perform cleaning of the conductor.

- ① In areas where you can reach, hold the pulling fixture and perform cleaning.
- ② In areas where you cannot reach, attach a pulling ring to the pulling fixture or cart, and use a rope, etc. to perform cleaning.

① When hands can reach: ② When hands cannot reach:

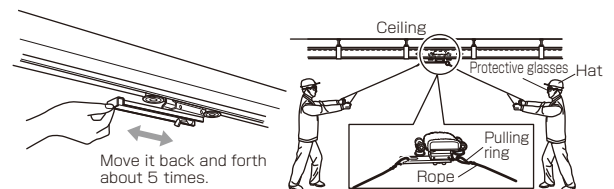

■ Replacing the cleaning pad

Wrap the base with the cleaning pad and put it on top of the car and fasten the wing bolt.

This cleaning pad is available at cost.

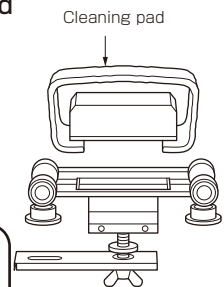

Notes

- Replace the cleaning pad with a new one when it is deformed into concave shape.

⚠ Caution

- Be sure to switch off the power to the duct when using the conductor cleaner. Failure to do so may cause electric shock or short-circuiting.
- Always remove the conductor cleaner from the duct after cleaning.
- When cleaning, be sure to wear protective equipment.
- Cleaning should be performed approximately once every 3 months. However, this should be increased or decreased depending on your usage conditions.
- The cleaning pad should be replaced every 50m as a general criteria. Failure to do so may result in dirtying of the conductor due to abrasion by the cleaning pad.
- After removing the conductor cleaner from the duct, be sure to close the door of the drop-out duct securely.