

End tension insulator

Attached to both ends of the High-Tro-Reel unit to absorb expansion and contraction due to temperature fluctuations.
For 60A, 90A, 150A, and 200A.

Note: Can be used with lines 100m or less in length.

●With feed-in terminal (Cable side-out type).
For 60A, 90A, 150A and 200A.

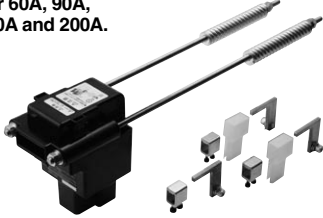

※3P(DH57032K)

●With feed-in terminal (Cable bottom-out type).
For 60A, 90A, 150A and 200A.

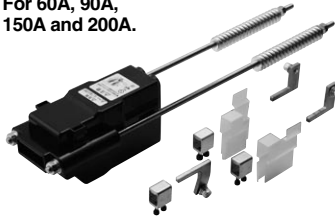

※3P(DH57034K)

●Without feed-in terminal.
For 60A, 90A, 150A and 200A.

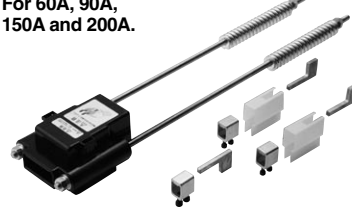

※3P(DH57132K)

After setting the High-Tro-Reel unit, the terminal, and the terminal plate in the end tension insulator. The terminal plate and the terminal where fixed bolt M6x12 was tightened with the specified torque cannot be used again.

Don't use them again.

Please inquire of store purchased when the terminal and the terminal plate are necessary.

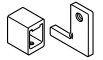

●With feed-in terminal (Cable side-out type).
For 60A, 90A, 150A and 200A.

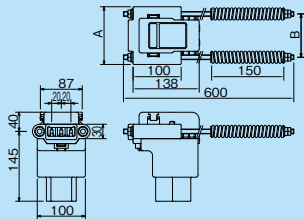

Drawing shows a 3P end tension insulator.

●With feed-in terminal (Cable bottom-out type).
For 60A, 90A, 150A and 200A.

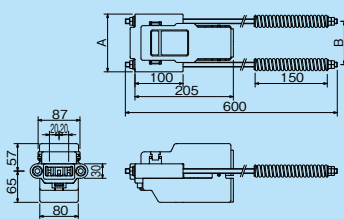

●Without feed-in terminal.
For 60A, 90A, 150A and 200A.

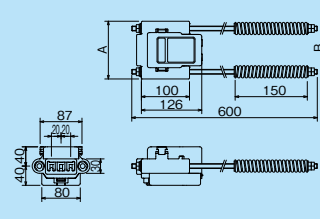

	A	B
3P	120	90
4P	140	110
5P	160	130

●With feed-in terminal (Cable side-out type)

Cat. No.	Type	Weight (kg)	Units per box	Units per carton
UL DH57032K	For 3P	1.8	—	1
UL DH57042K	For 4P	2.1	—	1
DH57052	For 5P	2.4	—	1

●With feed-in terminal (Cable bottom-out type)

Cat. No.	Type	Weight (kg)	Units per box	Units per carton
UL DH57034K	For 3P	1.8	—	1
UL DH57044K	For 4P	2.1	—	1
DH57054	For 5P	2.4	—	1

●Without feed-in terminal

Cat. No.	Type	Weight (kg)	Units per box	Units per carton
UL DH57132K	For 3P	1.7	—	1
UL DH57142K	For 4P	2.0	—	1
DH57152	For 5P	2.3	—	1

End tension insulator for lateral movement

Tension insulator for use in short-distance line internal wiring such as in cranes. Since the end tension insulator comes equipped with inward-facing springs for tension application, the High-Tro-Reel provides the most effective use of factory space.

For installation procedures, please refer to the specialized installation manual.

●With feed-in terminal (Cable side-out type).
For 60A, 90A, 150A and 200A.

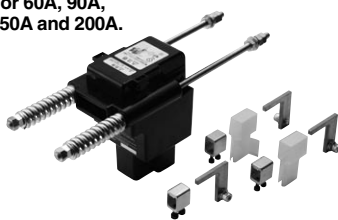

※3P(DH57033K)

●With feed-in terminal (Cable bottom-out type).
For 60A, 90A, 150A and 200A.

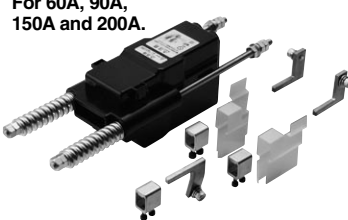

※3P(DH57035K)

●Without feed-in terminal.
For 60A, 90A, 150A and 200A.

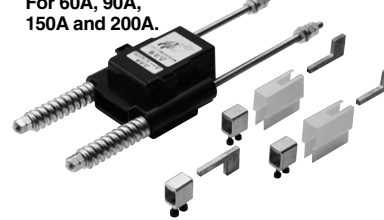

※3P(DH57133K)

After setting the High-Tro-Reel unit, the terminal, and the terminal plate in the end tension insulator. The terminal plate and the terminal where fixed bolt M6x12 was tightened with the specified torque cannot be used again.

Don't use them again.

Please inquire of store purchased when the terminal and the terminal plate are necessary.

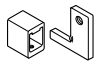

●With feed-in terminal (Cable side-out type).
For 60A, 90A, 150A and 200A.

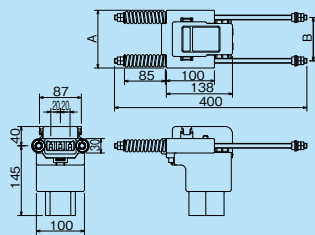

Drawing shows a 3P end tension insulator.

●With feed-in terminal (Cable bottom-out type).
For 60A, 90A, 150A and 200A.

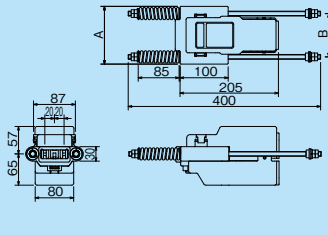

●Without feed-in terminal.
For 60A, 90A, 150A and 200A.

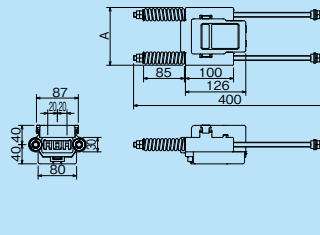

	A	B
3P	120	90
4P	140	110
5P	160	130

●With feed-in terminal (Cable side-out type)

Cat. No.	Type	Weight (kg)	Units per box	Units per carton
UL DH57033K	For 3P	1.5	—	1
UL DH57043K	For 4P	1.8	—	1
DH57053	For 5P	1.8	—	1

●With feed-in terminal (Cable bottom-out type)

Cat. No.	Type	Weight (kg)	Units per box	Units per carton
UL DH57035K	For 3P	1.5	—	1
UL DH57045K	For 4P	1.8	—	1
DH57055	For 5P	1.8	—	1

●Without feed-in terminal

Cat. No.	Type	Weight (kg)	Units per box	Units per carton
UL DH57133K	For 3P	1.4	—	1
UL DH57143K	For 4P	1.7	—	1
DH57153	For 5P	1.7	—	1

Joiner

Used to connect High-Tro-Reel units. Can also supply power from anywhere on the line (60A and 90A types).

●With feed-in terminal
For 60A and 90A



※4P(DH5724K2)

●Without feed-in terminal
For 150A and 200A



※4P(DH5727K1)

Cat. No.	Type	Rating	Weight (kg)	Units per box	Units per carton
UL DH5723K	For 3P, 60A/90A	3P·600V·90A	0.18	1	20
UL DH5724K2	For 4P, 60A/90A	4P·600V·90A	0.31	1	10
DH5725	For 5P, 60A/90A	5P·600V·90A	0.37	1	10
DH5726	For 3P, 150A/200A	3P·600V·200A	0.20	1	20
DH5727K1	For 4P, 150A/200A	4P·600V·200A	0.26	1	10

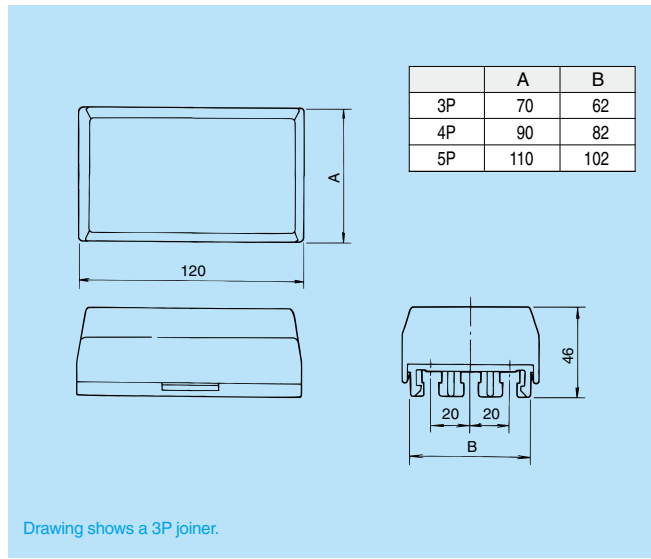

Center feed-in joiner

Used to feed power from anywhere on the line and connect the High-Tro-Reel units (150A and 200A types). For 150A and 200A.

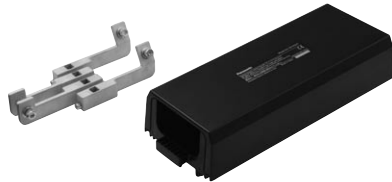

※4P(DH57271)

Cat. No.	Type	Rating	Weight (kg)	Units per box	Units per carton
DH57261	For 3P, 150A/200A	3P·600V·200A	1.9	—	1
DH57271	For 4P, 150A/200A	4P·600V·200A	2.2	—	1

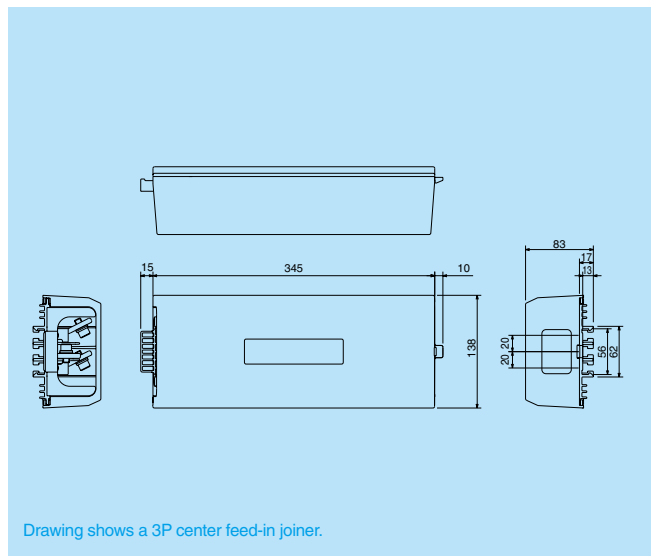

Hanger

UL Listed

It mounts main units on the structural materials. It can be used for non-tension type, too. For 60A, 90A, 150A and 200A.



※5P (DH5775K2)

Cat. No.	Type	Weight (kg)	Units per box	Units per carton
DH5773K2	For 3P	0.06	20	100
DH5774K2	For 4P	0.07	10	50
DH5775K2	For 5P	0.08	10	50

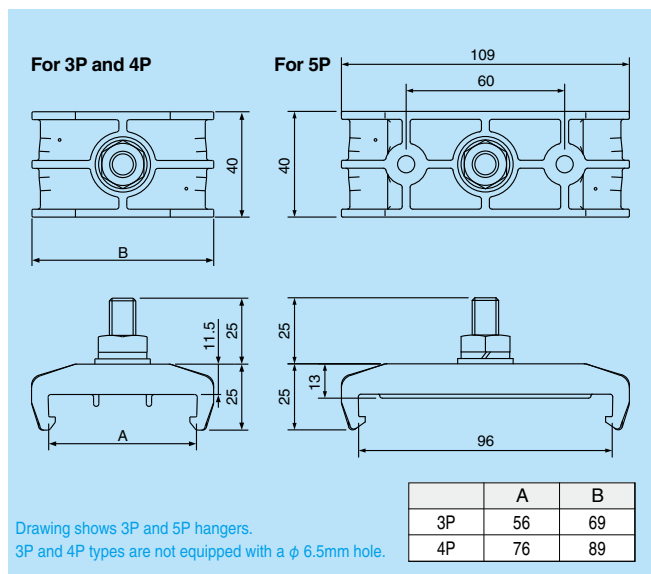

Collector arm

Attached to the moving equipment and used to supply power from the High-Tro-Reel unit to the equipment.

●Single type

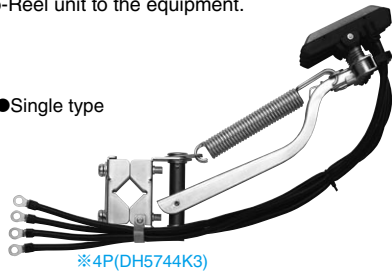

※4P(DH5744K3)

Cat. No.	Rating	Weight (kg)	Units per box	Units per carton
DH5743K3	3P·600V·30A	0.67	—	1
DH5744K3	4P·600V·30A	0.98	—	1
DH5745K2	5P·600V·30A	1.08	—	1
DH5746K2	3P·600V·60A	0.81	—	1
DH5747K2	4P·600V·60A	1.16	—	1
DH5748K2	5P·600V·60A	1.32	—	1
DH5741K2	3P·600V·100A	1.06	—	1
DH5742K2	4P·600V·100A	1.41	—	1



Collector arms can be linked together and used in tandem configuration when it is critical that the collectors are not separated from the wires.

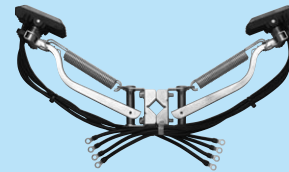

	A	Crimp-on terminal
30A	55	3.5-5S
60A	70	8-6
100A	95	14-6

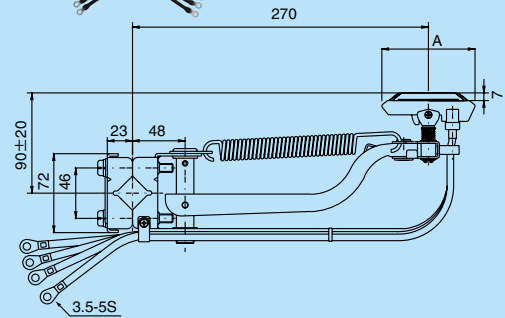

※Drawing shows 4P collector arm.

Collector arm support parts for transverse

- Applicable for 30A, 60A, and 100A collector arms.
- When installing a collector arm horizontally, mounted collector arm support parts for transverse on base of the collector arm as shown.



Cat. No.	Weight (kg)	Units per box	Units per carton
DH5249K	0.13	1	24

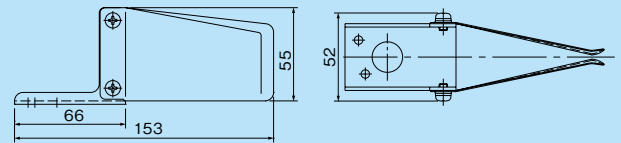

The above shows when it is installed.

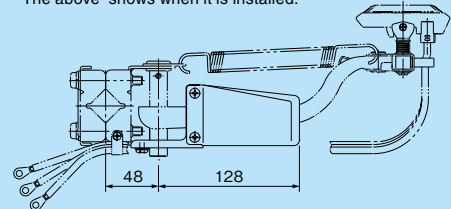

Collector (replacement parts)

The number of collectors in a set conforms to the number of poles. Replace collectors when they wear down to the replacement indication line (approx. 5,000km).



※3P(DH5783K1)

Cat. No.	Rating	Units per box	Units per carton
DH5783K1	3P·600V·30A	1	30
DH5784K1	4P·600V·30A	1	20
DH5785K1	5P·600V·30A	1	20
DH5786K1	3P·600V·60A	1	30
DH5787K1	4P·600V·60A	1	20
DH5788K1	5P·600V·60A	1	20
DH5781K2	3P·600V·100A	1	20
DH5782K2	4P·600V·100A	1	10

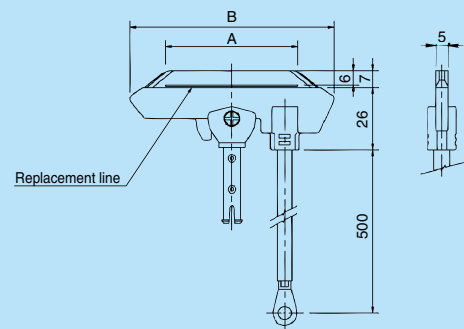

	A	B	Crimp-on terminal
30A	55	85	3.5-5S
60A	70	100	8-6
100A	95	125	14-6