

Installation Procedures for High-Tro-Reel (Non-Tension Type)

(Install explanation of this product is described with 3P and Installations of 4P and 5P, 6P like in the same way.)

Unit:mm

● Cross-section

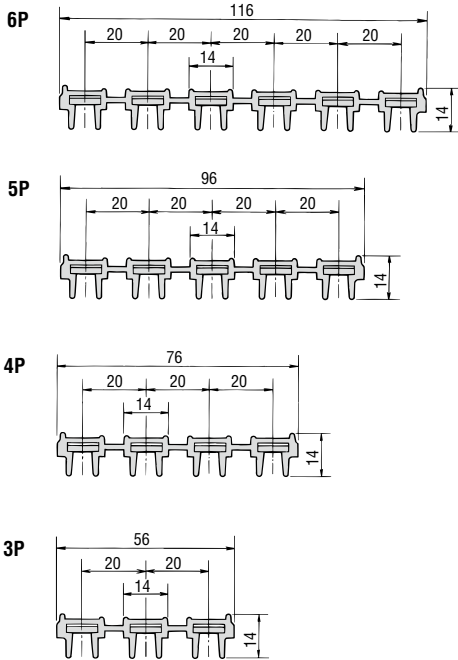

● Standard installation (For 5P type)

Normal installation

Lay horizontally

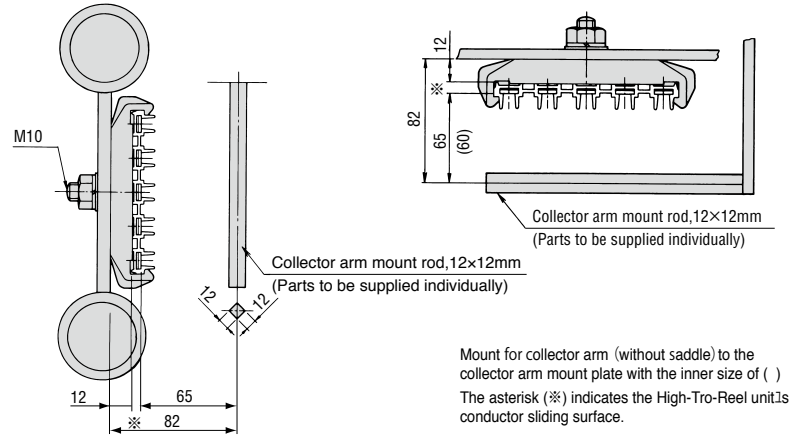

Unit : mm

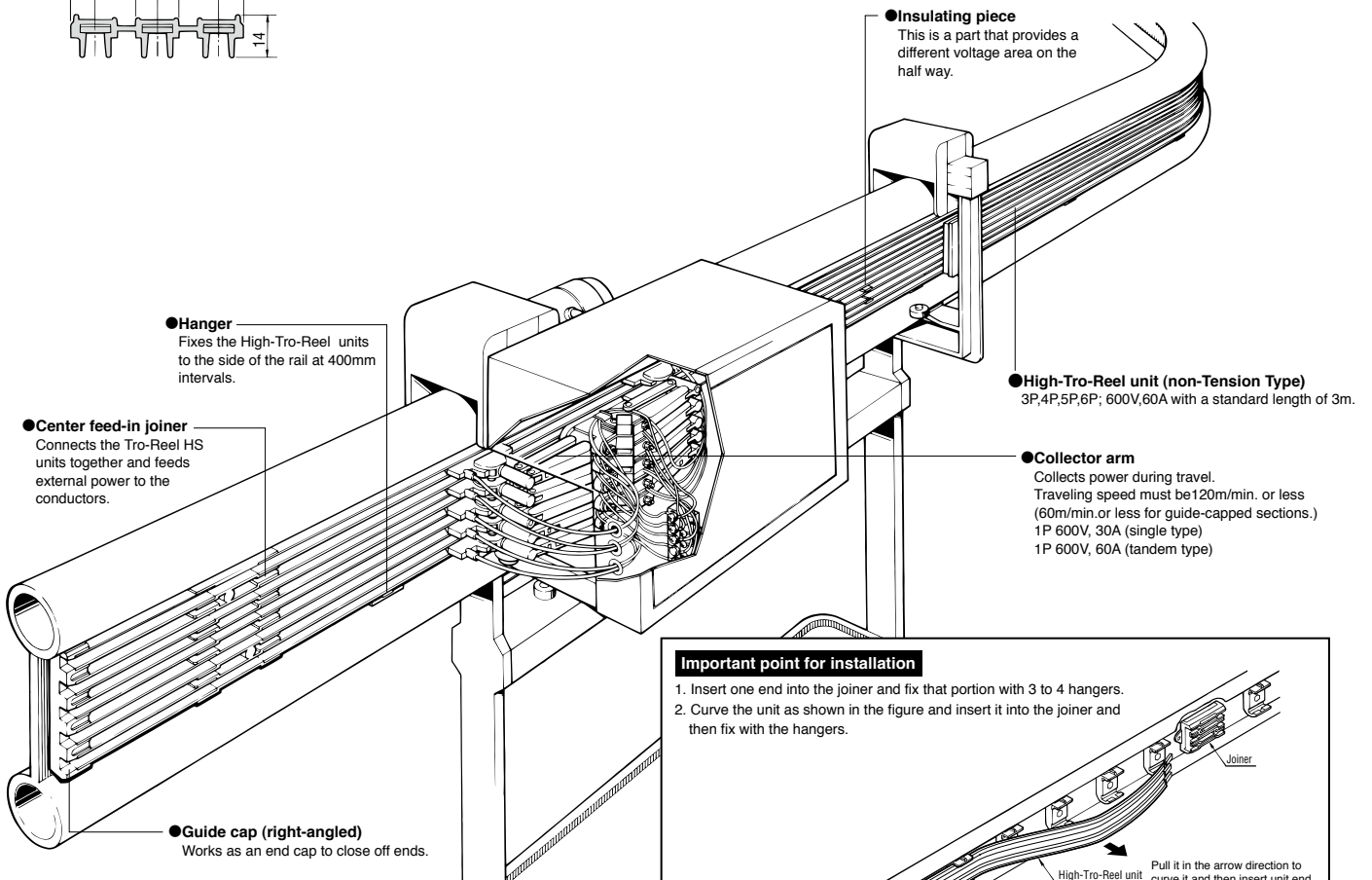

Important point for installation

1. Insert one end into the joiner and fix that portion with 3 to 4 hangers.
2. Curve the unit as shown in the figure and insert it into the joiner and then fix with the hangers.

